

VALVES

The purpose of a valve is to stop or control the flow of material through a piping system. Valves are manufactured in various configurations. Practically any type of end connection is available.

GATE VALVE

As the name implies this particular valve has a gate that moves perpendicular to flow of the service. In the up position it is open. In the down position it is closed. The flow is straight through so it does not lend itself for use as a metering valve. The gate valve is used mainly as an on-and-off valve.

Gate valves are furnished in screwed, socket weld, screwed by socket weld, raised face flange, flat face flange, RTJ face and butt weld end connections. Gate valve extras include:

1. Split, Flex or Solid Wedge
2. Stellite Seat & Disc
3. Rising or Non-Rising Stem

GLOBE VALVE

In the globe valve, the flow pattern is offset and not a straight through flow. This design affords a better closure than a gate valve and can be used for metering. All end connections previously mentioned in this manual are available.

Valves are supplied in a wide variety of materials. Smaller sizes: NPS 2 and under, are manufactured in both forged and cast material. Above NPS 2 are generally in cast material.

TRIM

Trim refers to stem, seat and disc in Gate Valves and Disc Plug in Globe Valves.

A variety of trims can be used on the seat, stem, or disc. 11% to 13% chrome (F6 410SS) is accepted as standard on most types of valves.

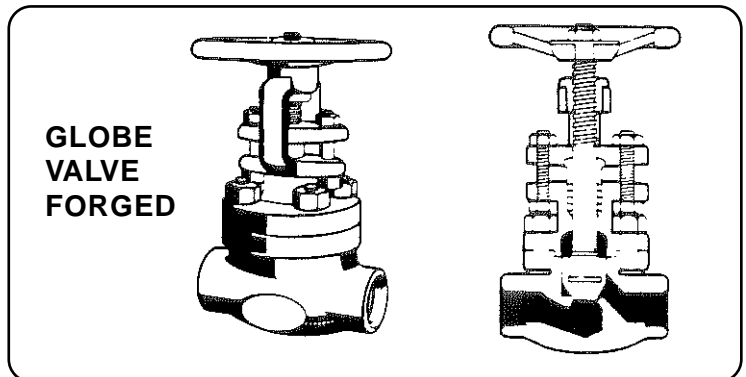
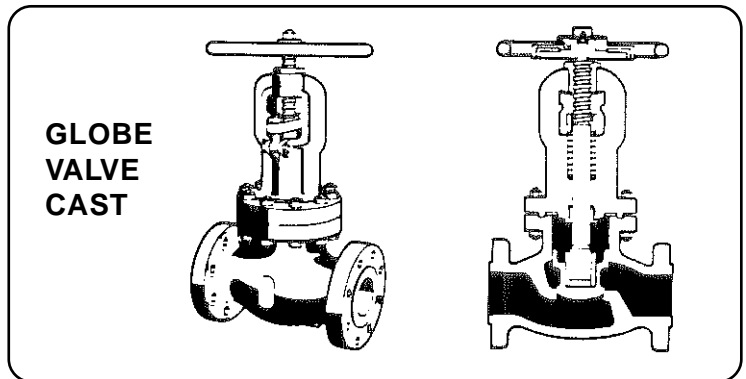
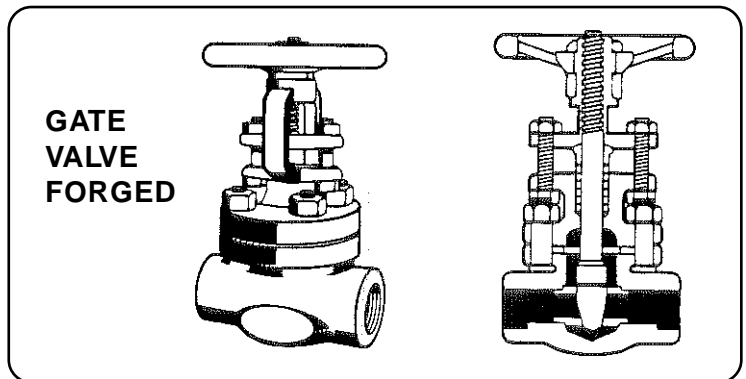
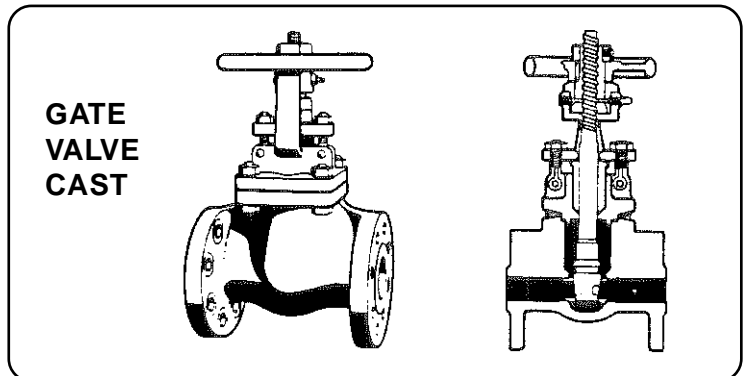

CHECK VALVE

This valve is used to stop back flow to the upstream side of the valve. The design is quite simple. A hinged door or ball is placed inside the valve. With the pressure coming upstream the door or ball is held open: when the pressure increases on the downstream side, it forces the door or ball to close, stopping any back flow.

The wide variety of check valves available makes this valve quite versatile:

HORIZONTAL SWING

Designed to operate in the horizontal position.

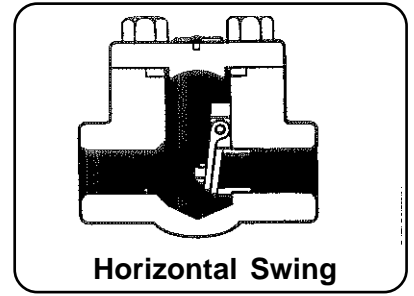
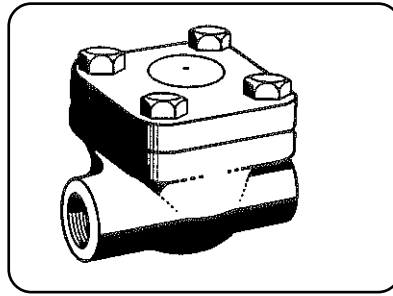

Horizontal Swing

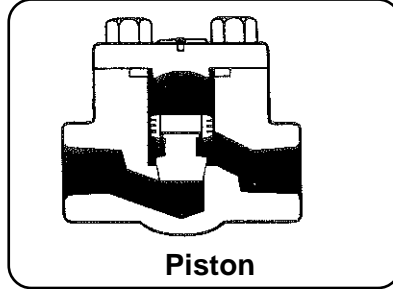

Piston

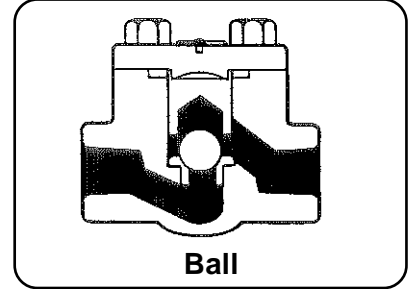

Ball

PISTON

This valve works up and down providing a strong, firm seal under high pressure conditions.

BALL

Uses a ball rather than a clapper.

BALL VALVE

(Reduced Pattern Design)

A ball is set between two seats, with a hole through the center. By turning the handle 90° you go from full on to full off. This design does not lend itself to metering. All end connections available.

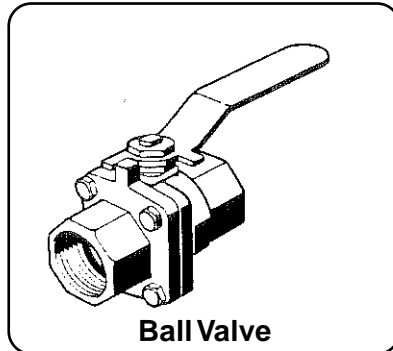

Ball Valve

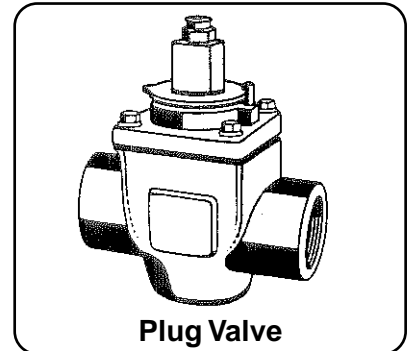

Plug Valve

BUTTERFLY VALVE

Similar to a ball valve except a door or rotating "gate" is used. A turn of 90° on the handle goes from full on to full off.

PLUG VALVE

A solid plug is set in the body with a hole through the center. The straight through flow pattern does not permit metering. Like Ball and Butterfly valves, a 90° turn on handle goes from full on to full off. All end connections available.

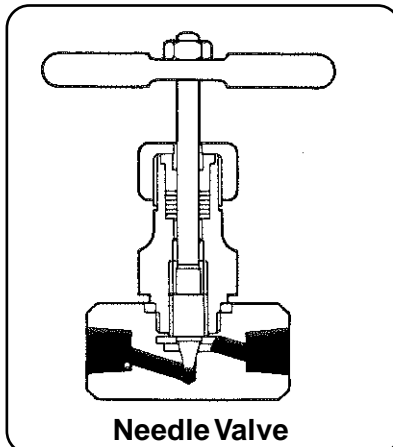

Needle Valve

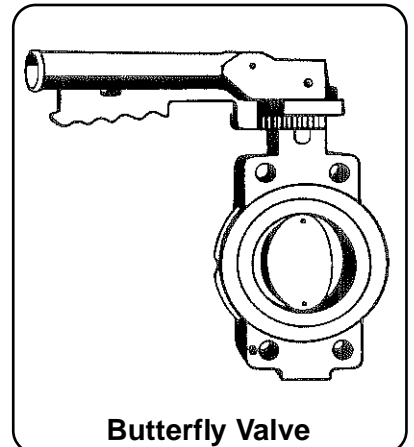

Butterfly Valve

NEEDLE VALVE

This valve is generally used on instrumentation because of its excellent control of flow. The stem is a tapered needle and the flow pattern is offset.